

# DIMENSIONS AND TECHNICAL SPECIFICATIONS

Internal version

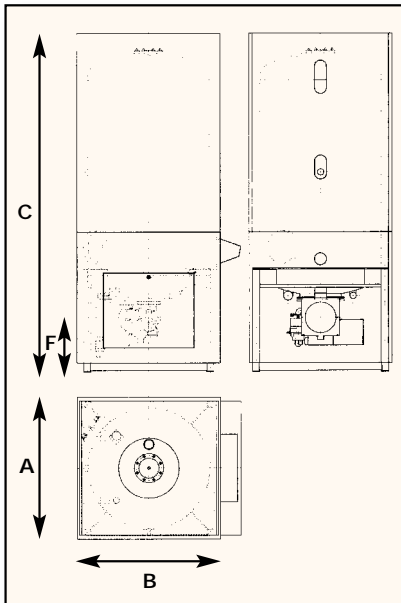

External versions

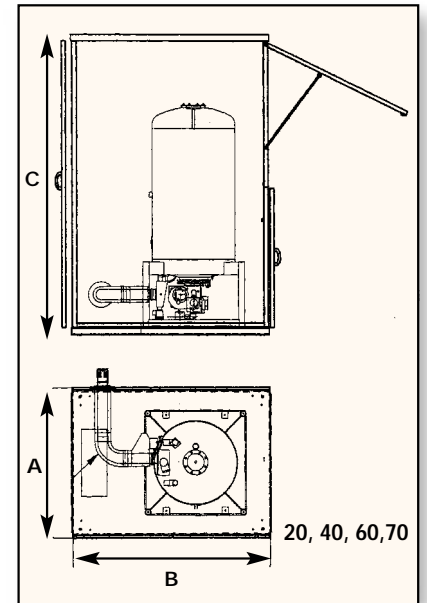
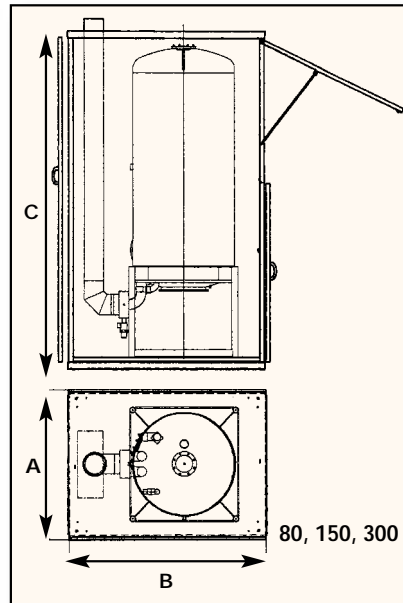

INTERNAL MODELS							
MODEL	20	40	60	70	80	150	300
<b>General specifications</b>							
Output (kW)	20	40	60	70	80	150	300
Capacity (l)	190	325	615	615	615	605	930
Weight (kg) empty	190	260	375	380	385	540	875
Electric supply (V)	1x240	1x240	1x240	1x240	1x240	1x240	3ø415
Electric load (W)	50	75	75	200	200	250	550
<b>Water flow</b>							
Continuous flow							
At 45° C (Δt 30° C) l/hr	573	1146	1720	2006	2293	4300	8600
At 65° C (Δt 50° C) l/hr	344	688	1032	1204	1376	2580	5160
In 10 min DHW at 65°C l	228	407	725	754	782	974	1697
First hr Δt 50°C l	515	980	1585	1757	1929	3124	5997
Recovery time (min) Δt 50° C	33	28	36	31	27	14	11
<b>Gas flow rates</b>							
G20 m³/hr	2	4	6	7	8,1	15,1	30,2
G25 m³/hr	2,3	4,7	7	8,2	9,4	17,6	35,2
G31 m³/hr	0,8	1,6	2,3	2,7	3,1	5,8	11,7
<b>Dimensions</b>							
A/B – Width/Depth mm	863/885	863/885	945/945	945/945	945/945	945/945	1075/1055
C – Height mm	1800	1800	2250	2250	2250	2500	3060
Hot water outlet mm	1682	1714	2135	2135	2135	2394	2971
F – Flue outlet mm	288	269	360	360	360	394	636
Minimum gap for access (with feet mounted) mm	800	800	860	860	860	860	1090
<b>Connection</b>							
Hot/cold water	1"	1 1/4"	2"	2"	2"	2"	2 1/2"
Returns	3/4"	1"	1"	1"	1"	1"	1 1/4"
Natural gas, low-pressure G20 20mbar	1/2"	1/2"	1/2"	1/2"	1/2"	1/2"	1 1/2"
Natural gas medium pressure G20, 300 mbar					1/2"	1/2"	1/2"
Propane (G31) 37 mbar	1/2"	1/2"	1/2"	1/2"	1/2"	1/2"	1/2"
Propane (G31) 148 mbar	Available on request						
Condensate drain	1 1/4"	1 1/4"	1 1/4"	1 1/4"	1 1/4"	1 1/4"	1 1/4"
Drain	1"	1"	1"	1"	1"	1"	1 1/4"
Flue outlet int. (Ø) (Conventional flue)	125	153	200	200	200	153	200

EXTERNAL MODELS					
MODEL	A mm	B mm	C mm	Weight empty	Weight full
Horizontal balanced flue	20	1160	1535	2300	470 600
	40	1160	1535	2300	530 855
	60/70	1160	1600	2550	710 1325
	80	1160	1600	2550	710 1325
	150	1160	1600	2550	860 1465
	300	1260	1860	3250	1400 2350



## MODEL SELECTION

There are a number of methods of calculating hot water requirements, many of them empirical and generally overgenerous in sizing of appliances, leading to unnecessary expenditure on equipment and installations.

Such over-sizing can be avoided with the **Aquagas** units as they achieve known constant output performance, and under heavy load they are not subject to the corrosion risks to conventional plant from low temperature operation initiating condensation.

### Sizing selection Guide for Aquagas Heaters

Please enquire for other specific needs

In situations where high demand peaks are experienced for short periods additional hot water storage should be considered.

	AQUAGAS 40	AQUAGAS 40 + 1000 l	AQUAGAS 60	AQUAGAS 60 + 1000 l	AQUAGAS 70	AQUAGAS 70 + 1000 l	AQUAGAS 80	2 AQUAGAS 80	AQUAGAS 80 + 1000 l	AQUAGAS 150	AQUAGAS 150 + 1000 l	AQUAGAS 300
<b>Hôtel ★</b> No. rooms	39	75	63	100	70	107	77	155	114	126	162	
<b>Hôtel ★★</b> No. rooms	29	56	48	75	53	80	58	116	85	94	121	181
<b>Block of flats</b> No. of 3 room flats	35	49	55	69	63	77	71	142	85	126	140	248
<b>Old people's home</b> Nb of beds	92		144		163		182	365		315		
<b>Private hospital</b> No. beds	62		100		111		122	244		198		
<b>Student hostels</b> No. residents	98		160		178		196	392		300		
<b>Commercial kitchen</b> No. of users	285		472		510		559	1118		789		
<b>Restaurant</b> No. covers	137		226		247		268	536		422		
<b>Camp site</b> No. showers No. pitches	6 60		10 95		12 108		13 120	27 240		23 208		
<b>Sports centre</b> No. showers No. users	7 21		13 39		13 39		14 42	28 84	23 69	18 54	34 102	

1 - In order to preserve water quality and to provide maximum resistance to corrosion, matched hot water tanks, constructed in austenitic stainless steel, are available built to the same high standards as the Aquagas Heaters.

2 - Technical information on achieving the most effective connection of the Water heater and the storage tank is available on request.



# DIRECT GAS FIRED CONDENSING HOT WATER HEATERS

STAINLESS STEEL ♦ CONVENTIONAL OR BALANCED FLUE

## AQUAGAS

20 to 300 kW



GAS

**AQUAGAS**

CONDENSING

**APPLICATIONS**

**AQUAGAS** hot water heaters are designed to meet the **hot water** needs of domestic, commercial, industrial and process industry users. They can be installed in all types of buildings, from residential blocks to large commercial buildings, such as hotels and factories.

The product has been tried and tested for over 20 years in service, proving its efficiency, reliability and robustness in a wide variety of applications. A programme of continuous development ensures that the heaters remain at the forefront of technology in both construction and performance.

The **AQUAGAS** units have gained an enviable reputation throughout Europe, with installations in the UK, France, Belgium, the Netherlands and Germany.

**DESIGN CONCEPT**

The blown gas burner is mounted at the base of the heater, firing upwards into a **vertical stainless steel** combustion chamber. At the top of this central chamber the combustion gases roll over and travel downwards through one, or two, stainless steel serpentine coils ; finally exiting through a common **flue box**, located in the lower section of the appliance. Condensate arising from the cooling combustion gases is drained off via a water trap at the base of the flue box.

The combustion chamber and coil assembly is mounted within a stainless steel outer shell, which contains the water to be heated. The heated water rises in the outer shell, discharging at the top of the heater.

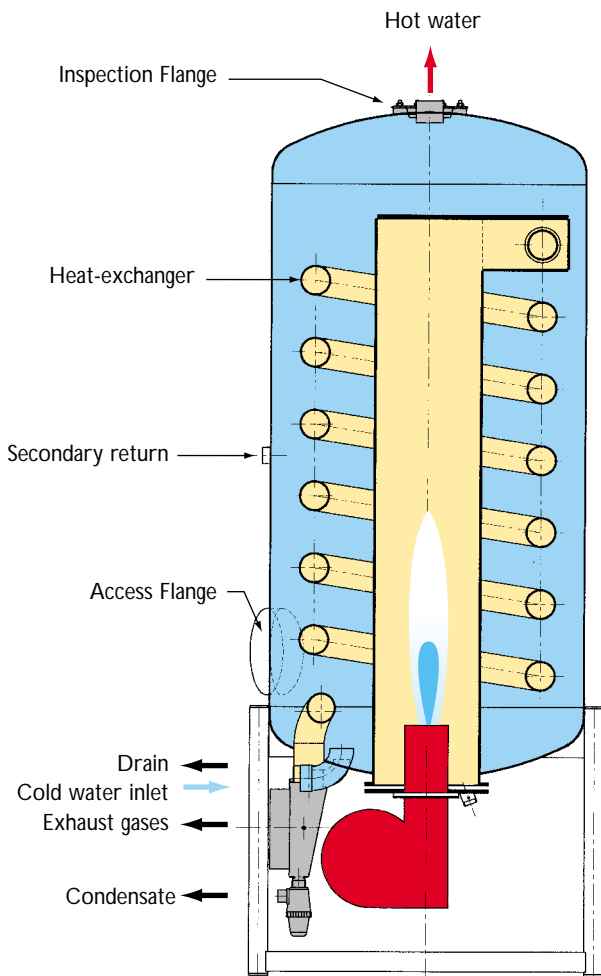

**WATER SUPPLY**

**AQUAGAS** hot water heaters are suitable for use with **Vented** (cistern fed) or **Unvented** (mains pressure) supplies. For unvented use a separate cold water filling kit is supplied, for connection, in-line, on the cold water supply to the heater, together with a pressure & temperature relief valve for fitting in the hot flow outlet from the heater.

## TECHNICAL SPECIFICATIONS

### ◆ All AQUAGAS Heaters are equipped with :

- a vertical cylindrical combustion chamber
- one (or two) serpentine coils with common flue box
- an outer shell, constructed entirely in austenitic stainless steel for working pressures up to 7-bar, with two inspection/cleaning access flanges. One at the top and one on the side of the shell.
- a stainless steel flue box.
- single or two stage blown gas burner, depending on model (2-stage optional on 150 model, 2-stage standard on the 300 model)
  - automatic electric ignition
  - ionisation flame control
  - multibloc gas valve
- control panel incorporating :
  - on / off switch
  - regulating thermostat
  - limit Thermostat - to prevent excessive temperature rise under low volume intermittent water draw down
  - overheat safety thermostat
  - overheat warning light
  - burner lock out light
- aluminium foil wrapped, glass fibre, shell insulation
- stove enamelled panel casings.

### ◆ Gas supply :

- for all low pressure models (20 to 300 kW)
  - natural gas at 21 mbar (G20)
  - propane at 37 mbar (G31)
- for all the 80, 150 and 300 kW models with medium pressure burners
  - natural gas at 300 mbar
  - propane at 148 mbar

### ◆ Appropriate combustion product evacuation system :

All the models have CE approval for connection to :

- a conventional flue (B23)
- a horizontal balanced flue (C13)
- a vertical balanced flue (C33)

## VERSIONS FOR EXTERNAL INSTALLATION :

For such applications the appliance is supplied in a weatherproof casing. A lockable door on the front panel gives access to the burner, the safety valve and the gas feed. The rear panel is removable. The heater must be installed on a galvanised steel plinth, which has been pre-drilled with access holes for connection of the pipework into the building. The whole unit, plinth and heater, is pre-assembled for ease of installation. Four lifting hooks are provided on the assembly.

Additional 100mm thick glass fibre insulation is fitted to the unit for extra protection, together with electrically heated banding.

CONVENTIONAL FLUE

**AQUAGAS**

BALANCED FLUE

## 8 GOOD REASONS FOR CHOOSING AQUAGAS

### 1 – Energy savings

- 105 % operating efficiency based on net calorific value, with water heated to 65 °C.
- Negligible standing losses :

Model	Losses
20	150 W
40	200 W
60, 70, 80, 150	290 W
300	420 W

- Automatic ignition - no pilot light.

In total, for the same hot water production:

- Gas savings of at least 20% in comparison with standard gas fired hot water heaters
- Gas and electricity savings of 15 to 25% in comparison with indirect systems where water is heated via a boiler.

### 2 – Water quality :

Water quality is unaffected by the stainless steel.

### 3 – Durability :

Austenitic stainless steel is a very high quality material and enables us to offer a **five-year** guarantee on all Aquagas Heaters. (provided that the chlorine concentration < 80 mg/l).

### 4 – Reduced maintenance :

With stainless steel a sacrificial anode is not required, avoiding costly replacements.

### 5 - Flexible siting :

The Aquagas Heaters can be installed in a variety of locations, with the convenience of conventional flues or balanced flues.

- In internal boiler rooms
- In external boiler rooms
- Externally (in weatherproof casings) on roofs, or beside existing buildings
- In commercial locations such as professional kitchens

### 6 - Flexible performance

- Storage capacity and powerful, fast reaction, burners give high flow rates at constant draw off.
- Rapid recovery of whole contents (31 minutes for the 70 Model)
- No minimum water supply temperature. In fact the lower the inlet temperature the higher the efficiency, due to the condensing operation.
- For commercial applications water can be heated to 90°C, if required.

### 7 – Healthy Water :

Legionella is prevented if the water is heated to a minimum of 65°C. Where required by local regulations, an optional automatic device that takes the water to 70°C at periodic intervals, can be fitted to the unit.

### 8 – Protection of the environment :

Carbon dioxide emissions are reduced by 25% compared with conventional equipment and the clean burners reduce NOx to 100mg/kWh.

## WATER QUALITY

The stainless steel used in the AQUAGAS hot water heaters has no chemical effects on the water. The quality of the incoming water is maintained throughout.

The heaters are suitable for use with soft or hard water. Where high temperature (> 65 °C) hot water is required, hard water should be softened.

Inspection and cleaning access flanges are provided in all the heaters to allow regular inspection and maintenance of the appliances.